

# 17-31GHz 4way Power Divider

P/N: MZP41731GB



## Description:

The power divider is a 4way power divider with a typical insertion loss of 1.3 dB and a typical isolation of 15dB across the frequency range of 17 to 31 GHz. The power divider can reach handling power 10W. Accept customization according to different needs.



- Radar Systems
- Communication Systems
- Receivers Systems

## Electrical Specifications ( +25°C ) :

Parameter	Min.	Typ.	Max.	Units
Frequency Range		17-31		GHz
Insertion Loss		1.3	1.6	dB
Isolation	15			dB
Input VSWR			1.8	-
Output VSWR			1.5	-
Phase Unbalance			±6	°
Amplitude Unbalance			±0.4	dB
Power Rating(FORWARD POWER)			10	W
Power Rating(REVERSE POWER)			1	W
Impedance		50		Ω
Connector		2.92-Female		
Material		Aluminum		
Weight		61g		
Package Sealing		Black Color(Standard)		

## Environmental Specifications:

- ※ Operational Temperature -45°C~+85°C
- ※ Storage Temperature -55°C~+105°C



OBSERVE  
PRECAUTIONS ELECTROSTATIC  
SENSITIVE DEVICES

MICZEN THCHNOLOGIES CO.,LTD.

Phone: +86 28 65003621 | E-mail: sales@miczen.com | Web: www.miczen.com

# 17-31GHz 4way Power Divider

P/N: MZP41731GB

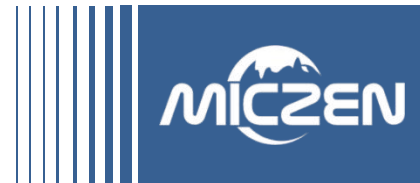

## ■ Outline Drawing

All Dimensions in mm (inches) Tolerance  $\pm 0.25$  (0.01)

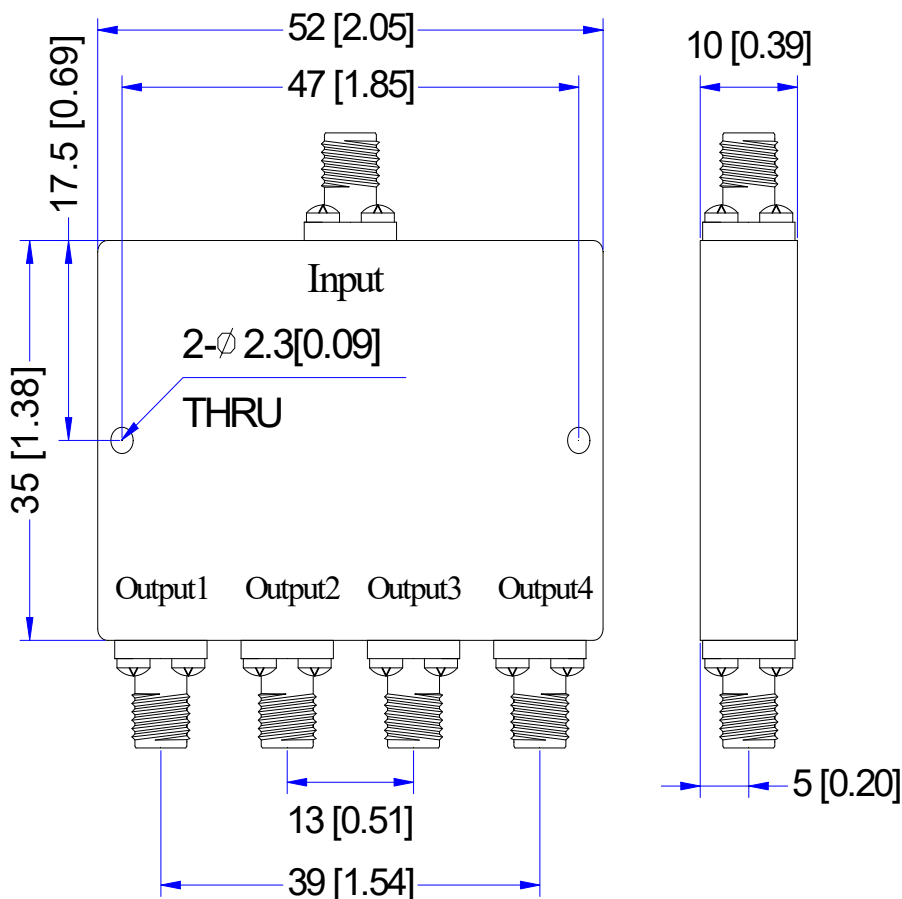

### NOTE:

1. The product is designed to meet environmental ratings but not tested. If you need to test environmental condition, please contact our sales department.
2. Miczen technologies co., Ltd. reserves the right to change the above information without notice.

MICZEN THCHNOLOGIES CO.,LTD.

Phone: +86 28 65003621 | E-mail: sales@miczen.com | Web: www.miczen.com

# 17-31GHz 4way Power Divider

P/N: MZP41731GB



## Performance Plot

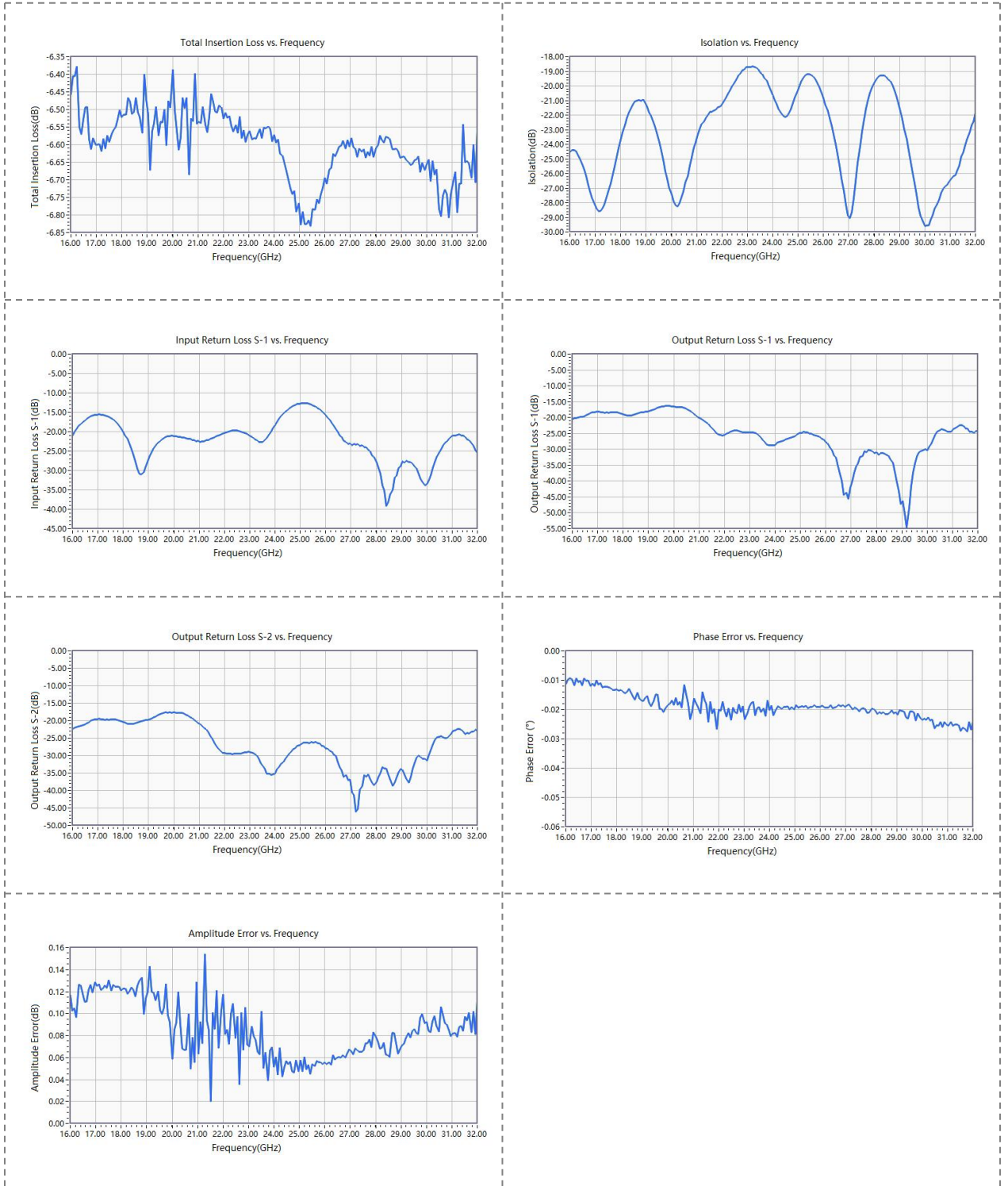

MICZEN THCNLOGIES CO.,LTD.

Phone: +86 28 65003621 | E-mail: sales@miczen.com | Web: www.miczen.com