

0.8-2.5GHz 2way Power Divider

P/N: MZP2008025GA



Description:

The power divider is a 2way power divider with a typical insertion loss of 0.3dB and a typical isolation of 21dB across the frequency range of 0.8 to 2.5 GHz. The power divider can reach handling power 30W. Accept customization according to different needs.



- Radar Systems
- Communication Systems
- Receivers Systems

Electrical Specifications (+25°C) :

Parameter	Min.	Typ.	Max.	Units
Frequency Range		0.8-2.5		GHz
Insertion Loss		0.3	0.4	dB
Isolation	20	21		dB
Input VSWR			1.3	-
Output VSWR			1.2	-
Phase Unbalance			±2	°
Amplitude Unbalance			±0.2	dB
Forward Power Handle Capability		30		W
Reverse Power Handle Capability		2		W
Impedance		50		Ω
Input/Output Connector		SMA-Female		
Material		Aluminum		
Weight		25g		
Package Sealing		Gray Color(Standard)		

Environmental Specifications:

- ※ Operational Temperature -45°C~+85°C
- ※ Storage Temperature -55°C~+105°C



OBSERVE
PRECAUTIONS ELECTROSTATIC
SENSITIVE DEVICES

MICZEN THCHNOLOGIES CO.,LTD.

Phone: +86 28 65003621 | E-mail: sales@miczen.com | Web: www.miczen.com

0.8-2.5GHz 2way Power Divider

P/N: MZP2008025GA



■ Outline Drawing

All Dimensions in mm (inches) Tolerance ± 0.25 (0.01)

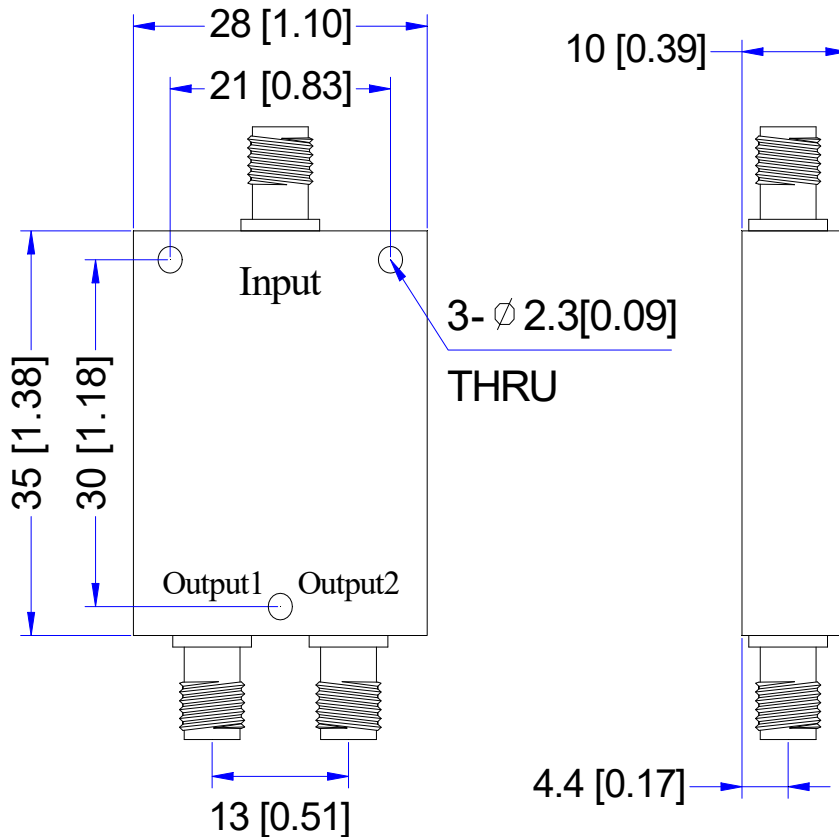

NOTE:

1. The product is designed to meet environmental ratings but not tested. If you need to test environmental condition, please contact our sales department.
2. Miczen technologies co., Ltd. reserves the right to change the above information without notice.

MICZEN THCHNOLOGIES CO.,LTD.

Phone: +86 28 65003621 | E-mail: sales@miczen.com | Web: www.miczen.com

0.7-2.7GHz 4way Power Divider

P/N: QLP4007027GB



Performance Plot

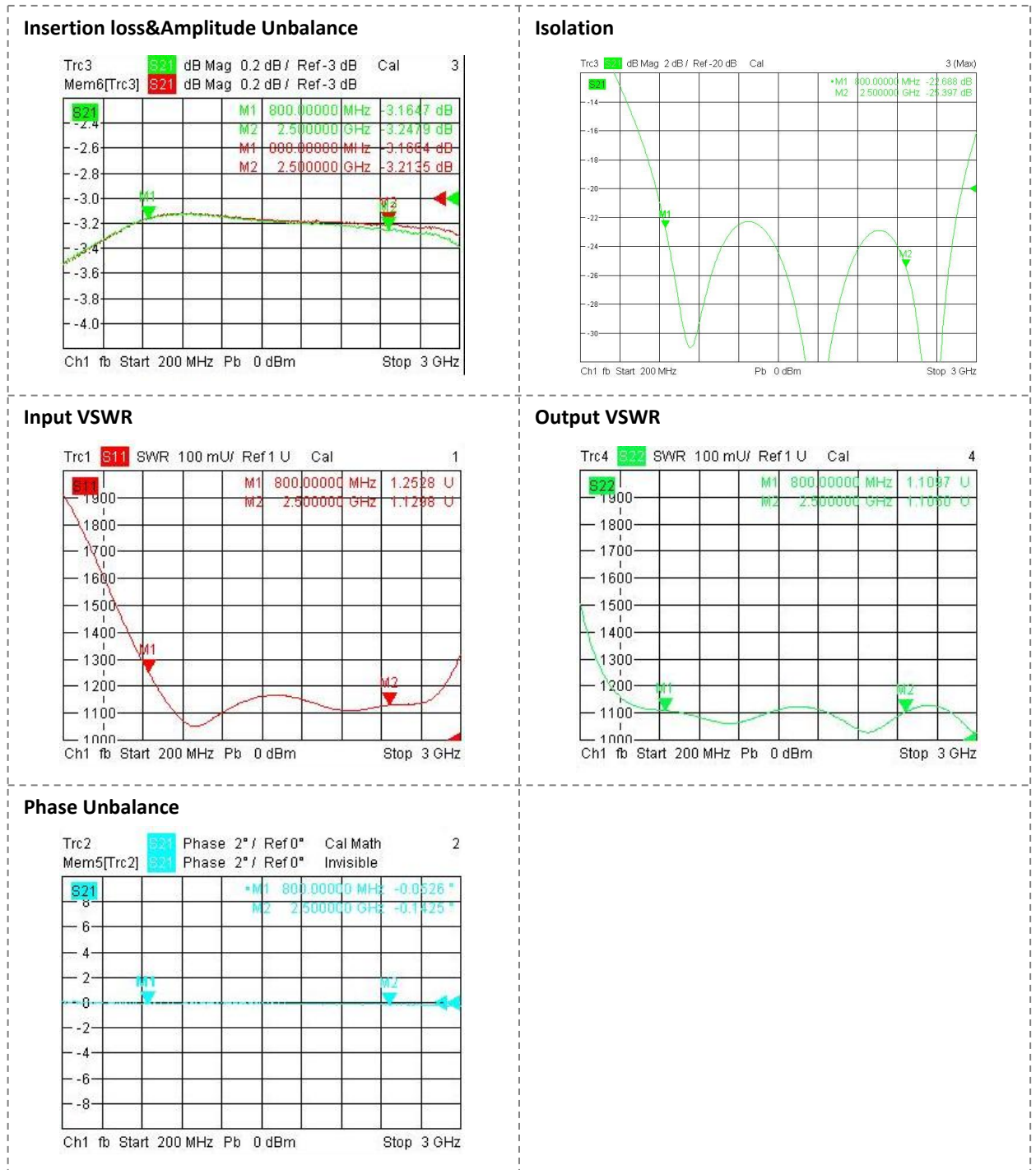

MICZEN THCNOLOGIES CO.,LTD.

Phone: +86 28 65003621 | E-mail: sales@miczen.com | Web: www.miczen.com